

## SMD Choke Coils

Series: **N**  
 Type: **ELC6GN**



Type ELC6GN

### ■ Features

- Low DC resistance and large current capability

### ■ Recommended Applications

- DC-DC converter circuitry for computer peripherals and cellular phones.
- Chopper circuit decoupling chokes for DC-DC converter circuitry

### ■ Standard Packing Quantity

- 1000 pcs./Reel

### ■ Explanation of Part Numbers

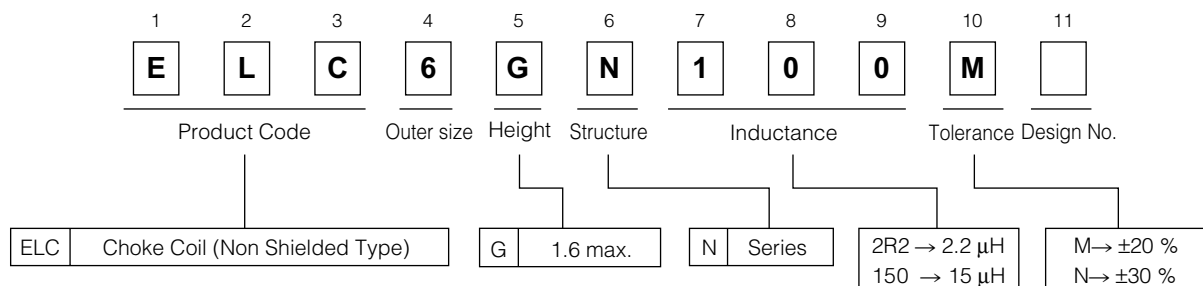

### ■ Dimensions in mm (not to scale)

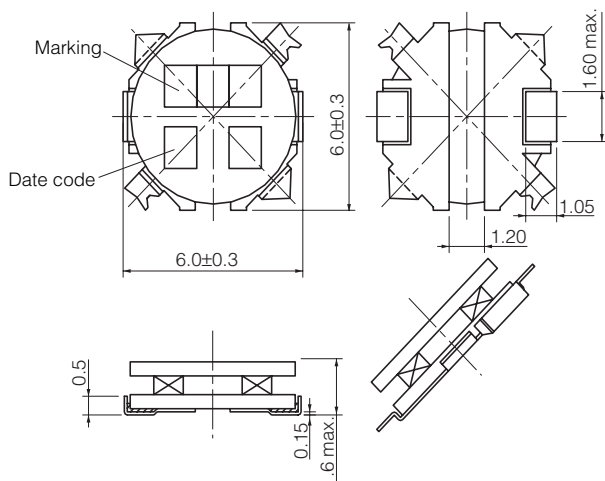

### ■ Recommended land patterns in mm (not to scale)

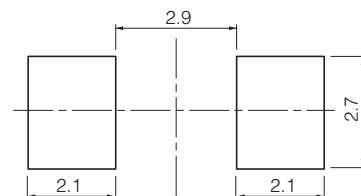

### Standard Parts

Part Number	Inductance (100 kHz)		R <sub>DC</sub> (at 20 °C)		*Rated Current (mA max.)	Marking
	(μH)	Tol.	(mΩ)	Tol.		
ELC6GN1R2N	1.2	±30 %	38	±20 %	2700	1R2
ELC6GN2R2N	2.2		47		2400	2R2
ELC6GN3R3N	3.3		66		2000	3R3
ELC6GN4R7N	4.7		94		1650	4R7
ELC6GN6R8N	6.8		120		1400	6R8
ELC6GN100M	10.0	±20 %	160		1200	100
ELC6GN220M	22.0		330		800	220
ELC6GN330M	33.0		470		600	330
ELC6GN470M	47.0		660		550	470
ELC6GN560M	56.0		740		500	560
ELC6GN680M	68.0		960	450	680	

\* Current: This indicates the value of current when the inductance is 70% of nominal value and case temperature has risen 45 °C (at 20 °C)

### Embossed Carrier Tape Dimensions in mm (not to scale)

